

FIBER MANAGEMENT SYSTEMS



Customer Premise Cabinet

Opterna CP series wall box comes with a very compact wall mountable Fiber Distribution solution, particularly designed for indoor/ customer premises installations in FTTx applications.

The unique double-hinged design ensures separation between the incoming side and distribution side, i.e. the service provider and client sides. This also allows independent access to both these sides separately.

Removable adaptor plates (SIX-PACKS) enable easy interchangeability between different types of adaptors.

The enclosure is made of sheet steel and has a robust construction. The standard product comes with grommets mounted at cable entry slots, but are dimensioned to suit a standard M20 cable gland.

The enclosure is provided with good quality locks with keys, which will prevent tampering by unauthorized persons. The unique design secures the interior of the enclosure from rodents/ insects etc. It also prevents entry of water and dust to certain limits.



Features & Advantages

- ❖ Easy installation
- ❖ Compact & requires less wall space
- ❖ Hooks for easy wall mounting
- ❖ Unique double-hinged design for separation as well as independent access to the Service provider side and Client side.
- ❖ Supplied with different adapter configurations - bracket designed with SC, LC, FC, SC Duplex, ST or MTRJ footprint.
- ❖ Protection from rodents & insects. Prevents dust ingress when used with cable glands (standard M20 gland – other sizes also available)
- ❖ Available with fiber management accessories including splice trays, fiber routing sticky clips, adapters and cable glands.
- ❖ Fully integrated and factory fiber managed solution available.

Applications

- ❖ FTTx Deployments for MDU (Multiple Dwelling Units)
- ❖ FTTx Deployments for independent living units.
- ❖ Other Customer Premises applications such as Communication closets, Computer Rooms etc.
- ❖ Fiber Communication Systems



Customer Premise Cabinet

Size & Dimensions

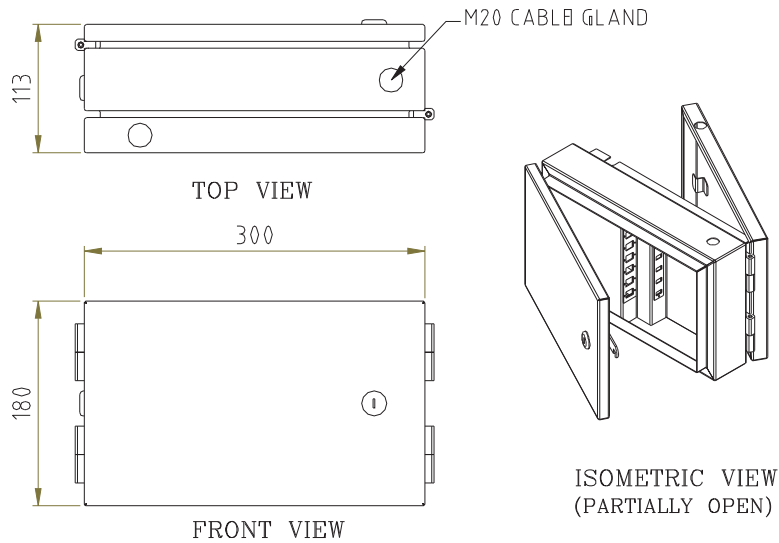

Ordering Information

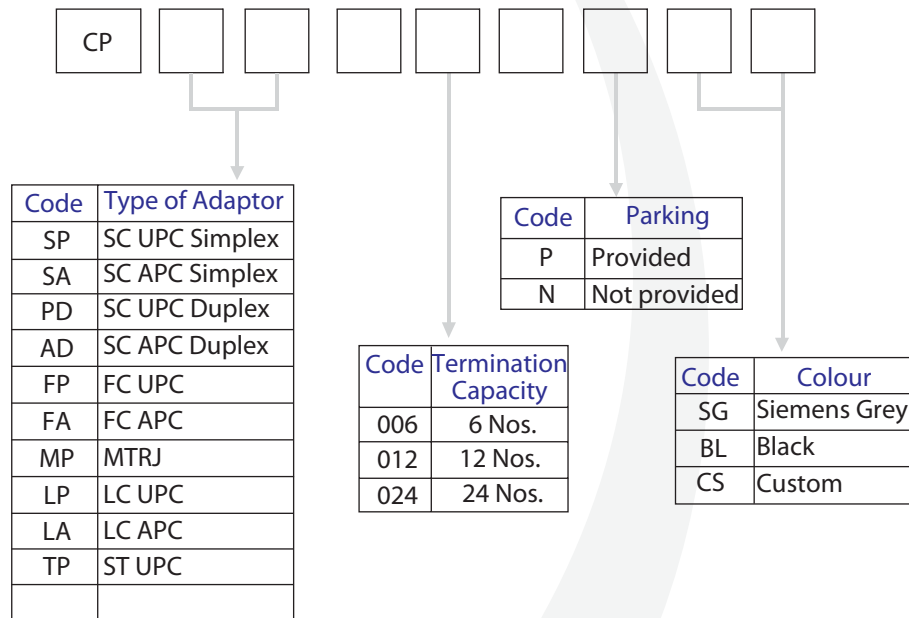

Note:

Termination capacity of 24 Nos. possible only when SC Duplex or LC adaptors are selected, without parking.